



FULL NDI®. NO COMPROMISES.



USER GUIDE
PART 1

Contents

IMPORTANT INFORMATION.....	4
WHAT'S IN THE BOX.....	5
OVERVIEW.....	5
Features.....	5
Camera Diagrams.....	6
Installing your Camera.....	7
Power Input.....	7
PoE Power Injector.....	8
Mounting the Camera.....	8
Use SDI video output.....	9
Starting the Camera.....	9
Setup Camera ID, Baud Rate and Control Protocol.....	9
Controlling the Camera.....	10
Adjusting and Setting with Menus.....	11
EXPOSURE Menu.....	11
WHITE BALANCE Menu.....	11
PICTURE Menu.....	12
LENS PARAMETERS Menu.....	12
SYSTEM SETUP Menu.....	13
Video Format.....	13
FUNCTION SETTING Menu.....	14
Dimensions.....	16

Operating Instructions

Thank you for purchasing our product. If there are any questions, please contact your authorized dealer.

Before operating the unit, please read this manual thoroughly and retain it for future reference.

Copyright

Copyright 2019 BirdDog Australia all rights reserved. No part of this manual may be copied, reproduced, translated, or distributed in any form or by any means without prior consent in writing from our company.

Trademark Acknowledgement

 **BirdDog** and other BirdDog's trademarks and logos are the property of BirdDog Australia. Other trademarks, company names and product names contained in this manual are the property of their respective owners.

- Trademarks and Registered Trademark Acknowledgement
- Microsoft, Windows, ActiveX, and Internet Explorer are registered trademarks of Microsoft Corporation in the U.S. and/or other countries.
- HDMI, the HDMI logo and High-Definition Multimedia Interface are the trademarks or registered trademarks of HDMI Licensing, LLC in the United States and other countries.
- Other trademarks, company names and product names contained in this manual are the property of their respective owners.

IMPORTANT INFORMATION

Legal Notice

Attention:

To ensure account security, please change the password after your first login. You are recommended to set a strong password (no less than eight characters).

The contents of this document are subject to change without prior notice. Updates will be added to the new version of this manual. We will readily improve or update the products or procedures described in the manual.

Best effort has been made to verify the integrity and correctness of the contents in this document, but no statement, information, or recommendation in this manual shall constitute formal guarantee of any kind, expressed or implied. We shall not be held responsible for any technical or typographical errors in this manual.

The product appearance shown in this manual is for reference only and may be different from the actual appearance of your device.

Due to uncertainties such as physical environment, discrepancy may exist between the actual values and reference values provided in this manual.

Use of this document and the subsequent results shall be entirely on the user's own responsibility.



WARNING!

Installation and removal of the unit and its accessories must be carried out by qualified personnel. You must read all of the Safety Instructions supplied with your equipment before installation and operation.

Warnings:

- If the product does not work properly, please contact your dealer. Never attempt to disassemble the camera yourself. (We will not assume any responsibility for problems caused by unauthorized repair or maintenance.)
- This installation should be made by a qualified service person and should conform to all the local codes.
- When shipping, the camera should be packed in its original packaging.
- Make sure the power supply voltage is correct before using the camera.
- Do not drop the camera or subject it to physical shock.
- Do not touch sensor modules with fingers. If cleaning is necessary, use a clean cloth with a bit of ethanol and wipe it gently. If the camera will not be used for an extended period of time, put on the lens cap to protect the sensor from dirt.

- Do not aim the camera lens at the strong light such as sun or incandescent lamp. The strong light can cause fatal damage to the camera.

Maintenance Precautions:

- If there is dust on the front glass surface, remove the dust gently using an oil-free brush or a rubber dust blowing ball.
- If there is grease or a dust stain on the front glass surface, clean the glass surface gently from the center outward using anti-static gloves or an oil-free cloth. If the grease or the stain still cannot be removed, use anti-static gloves or an oil-free cloth dipped with detergent and clean the glass surface gently until it is removed.
- Do not use organic solvents, such as benzene or ethanol when cleaning the front glass surface.

Regulatory Compliance

FCC Part 15

This equipment has been tested and found to comply with the limits for digital device, pursuant to part 15 of the FCC Rules. These limits are designed to provide reasonable protection against harmful interference when the equipment is operated in a commercial environment. This equipment generates, uses, and can radiate radio frequency energy and, if not installed and used in accordance with the instruction manual, may cause harmful interference to radio communications. Operation of this equipment in a residential area is likely to cause harmful interference in which case the user will be required to correct the interference at his own expense.

This product complies with Part 15 of the FCC Rules. Operation is subject to the following two conditions:

This device may not cause harmful interference.

This device must accept any interference received, including interference that may cause undesired operation.



LVD/EMC Directive

This product complies with the European Low Voltage Directive 2006/95/EC and EMC Directive 2004/108/EC.



WEEE Directive–2002/96/EC

The product this manual refers to is covered by the Waste Electrical & Electronic Equipment (WEEE) Directive and must be disposed of in a responsible manner.



WHAT'S IN THE BOX



1x BirdDog EyesA200



1x Accessories

Accessories (Optional)

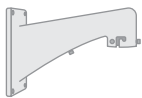

1x BD-A200-WM - Wall Mount



1x BD-A200-CM - Ceiling Mount

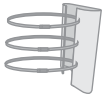

1x BD-A-PMA - Pole Mount



1x BD-A-CMA - Corner Mount

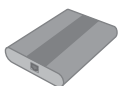

1x BD-A-PP80 - PoE Power Injector 80W

OVERVIEW

This user guide is suitable for the following models:

BirdDog Eyes A200

Features

- Resolution: Up to 1080P60, 1080i59.94
- NDI® Resolution: Up to 1080P60, 1080P30
- Zoom: Optical 30X
- Video Compression: H.264/MJPEG
- RS485/RS422 Communication, Auto compatible with PELCO D and VISCA Protocol
- Preset store positions and image parameters (iris, white balance, exposure, picture setting).
- 3D positioning, 120dB true WDR
- Video Output: SDI+IP, True Dual-Output SDI+IP Simultaneously
- Intelligent Adaptive IR Illumination up to 100Meters, IR ON/OFF is available.
- Outdoor Environmental Rating: IP67, Corrosion Resistant Treatment
- Various Image Functionalities: WDR, BLC, Defog, Day/Night
- Supports $\pm 120^\circ$ tilt / $\pm 360^\circ$ pan range, adaptive speed up to 150°/s
- Supports 255 Presets speed adaptive up 90°/s, 8 Cruises
- Support Zoom Lens Position and Direction Indicator on OSD
- Working temperature: -40°C to 60°C
- Operating Humidity: 80% suitable for use
- Rain wiper
- Supports Audio input, Audio output with NDI® streaming.
- Input Power: Provides AC24V and POE (BD PoE 80W Injector needed, optional)
- Firmware upgrade via USB2.0 or IP.

Camera Diagrams

NOTE: All cables are tagged to indicate their functions separately.

Use water proof / IP67 rated junction box/ connection box to protect the RJ45 and other connections.

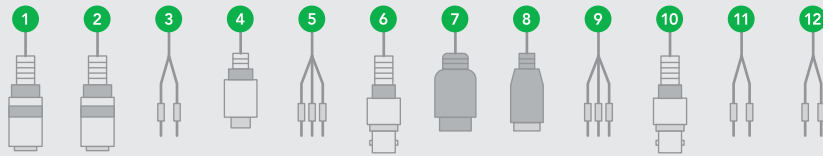
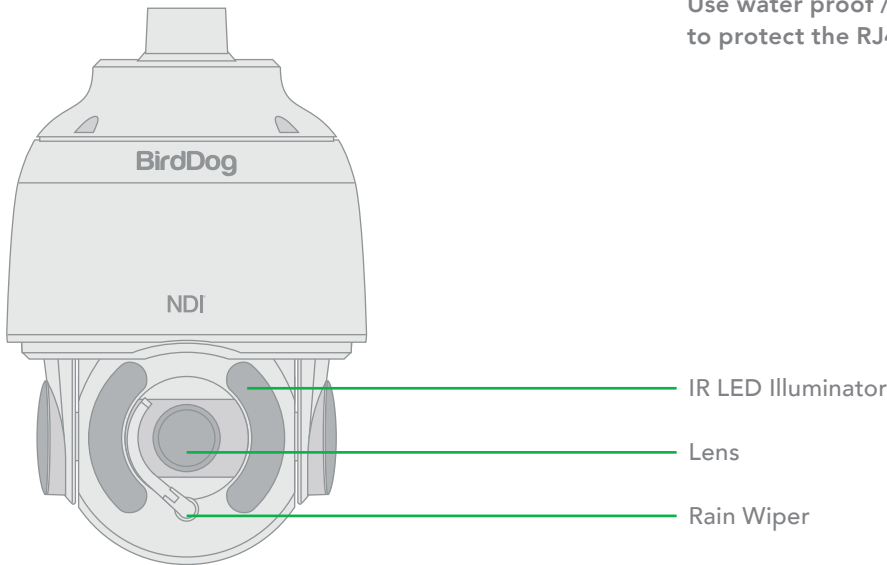

- 1. Audio Input • 2. Audio Output • 3. RS422 Connector (Combine with 11) • 4. Upgrade Interface • 5. Alarm Input
- 6. BNC Connector: 3G-SDI video output • 7. RJ45 Ethernet Port • 8. AUX DC12V Output • 9. AC Power Connector
- 10. BNC Connector: Analog video output • 11. RS485/RS422 Connector (Combine with 3) • 12. Alarm Output

Cable Connections

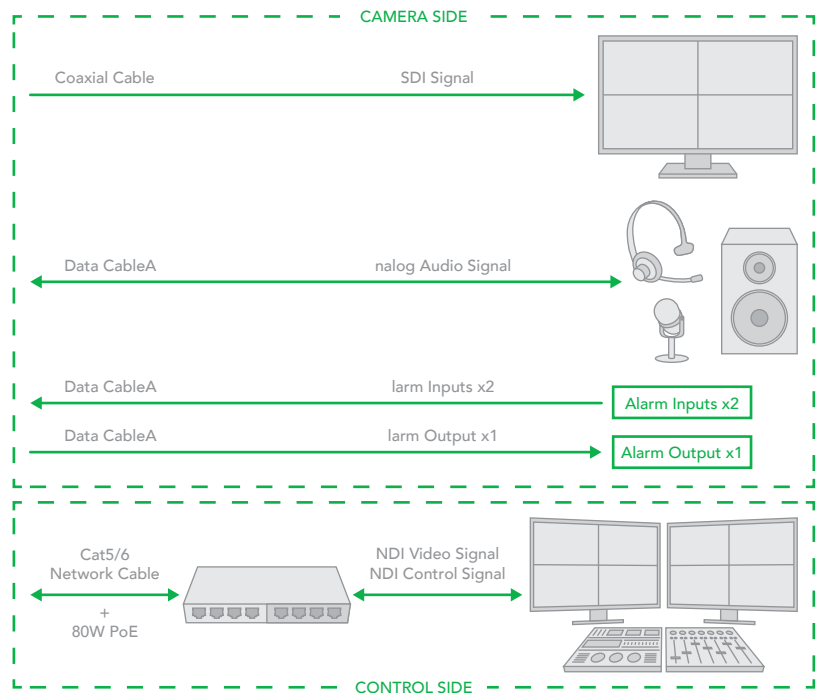
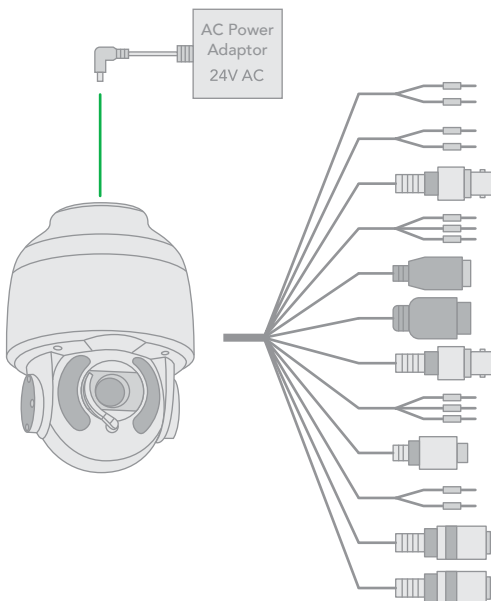

Installing Your Camera

The following diagrams are for your reference only. See the actual product to mount your camera.

Check Camera Components and Installation Conditions.

Before mounting your camera, check the device model number and included contents against the packing list to ensure components are complete.

Camera Structure:

1. Tail-Cable
2. Security Lock
3. Camera Body

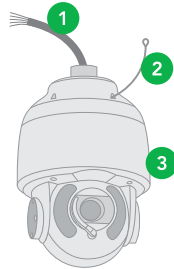

Important

- Verify the bearing capacity of the mounted position
- Verify that the mounted position meets the bearing requirements. Otherwise, you are advised to reinforce the mounted position for the device weight. For more information, see the product datasheet.
- Verify lightning protection and grounding requirements
- Select proper lightning protection devices for the power supply, video signal interfaces, and RS485 interfaces.
- Ground the terminal properly.

Cable Requirements

Network cable

10/100/1000 Mbps (Gig port) Ethernet Cat6/6a UTP cables are applicable to the ANSI/EIA/TIA-568A/B and ISO/D. Eight wires in the network cable need to be inserted in parallel into the top of the cable connector. The cable connector needs to be crimped in position. When the cable connector is in position, ensure that the metal pieces of the cable connector are parallel to each other and the clamp of the cable connector is intact.

SDI Signal Cable

In order to ensure the quality of the installation of the project, the HD-SDI and 3G-SDI signals have a high data transmission rate of digital signals, it is necessary to correctly select the appropriate cable model. In the process of installing a cable, it should be carefully and carefully, to avoid incorrect to fold, twist, bend the cable or to apply various kinds of stress to the cable, so that the signal can be transmitted along the cable smoothly. Different cable types have different physical characteristics, and the transmission length of the digital signal is not the same.

Power Input

BirdDog PTZ camera provides 24VAC power input.

Power Cable

Data listed in the below table is applicable to copper cables that use 24 VAC/24 VDC power supply. The item Core Diameter indicates the conductor diameter.

Power Loss on the Cable for Different Lengths and Different Core Diameters

Distance (m) \ Core Diameter (mm)	0.80	1.00	1.25	2.00
10	86	137	218	551
20	42	68	109	275
30	28	45	72	183
40	21	34	54	137
50	17	27	43	110
60	14	22	36	91
70	12	19	31	78
80	10	17	27	68
90	9	15	24	61
100	8	13	21	55
110	7	12	19	49
120	7	11	17	45
130	6	10	16	42
140	6	9	15	39
150	5	9	14	36
160	5	8	13	34
170	4	7	12	32
180	4	7	11	30
190	4	7	11	28
200	4	6	10	27

! NOTE: Power supply requirement is 24VAC 2.5 Amp to ensure proper functionality of PT motor and LED illumination. Using power supply lower than 24VAC 2.5Amp will cause camera crashing or insatiability.

Power Connector: Phoenix Connector Description

1. The anode and the cathode are not distinguished for phoenix connectors of red and black cables.
2. GND: yellow-green color.

Note: GND is used to ground the camera. Ensure that GND is connected to a reliable grounding point.



PoE Power Injector

Other than 24VAC power input, BirdDog PTZ camera provides PoE power as an optional power input.

For PoE power, you must use BirdDog 80W Power PoE Injector: model BL-PP80. It provides high PoE power up to the PTZ camera. Connect this PoE injector to a network switch and then run Ethernet cable for data transmission and power up the PoE PTZ camera (Specific model: A200 & A300) for distance up to 100 meters.

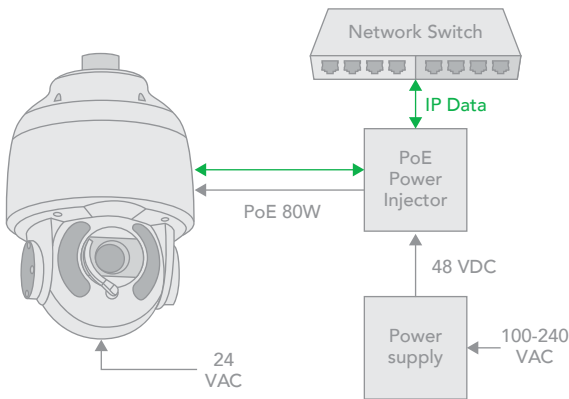

NOTE!

- Disconnect the power from the camera before mounting.
- Accessories such as the wall mount bracket and the pendant mount bracket may be necessary during mounting. For their model, refer to the accessory list recommended by your dealer.
- The wall bearing capacity and the bracket length must meet all onsite mounting requirements. You will need to select a mount type based the actual environment.

Mounting the camera

NOTE!

- When mounting the camera, please install the bracket adapter to the bracket first and then mount the camera to the bracket.
- Tighten all the screws to hold the camera securely.
- For waterproofing, apply sealant between the dome and the bracket, wall veneer slits, and leading-out holes of the wall.

Wall Mount

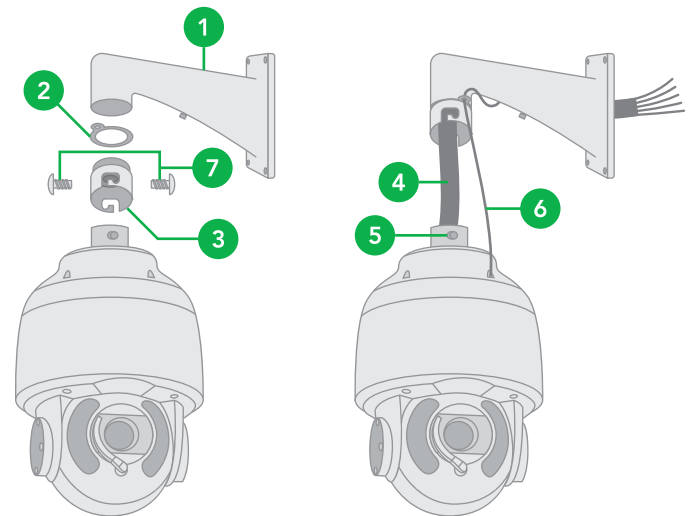

1. Install the wall mount bracket. Get the heads of necessary cable (Wall cable) through the bracket from the wall outside of the bracket.
2. Pull the wall cable out through the secure ring.
3. Pull the wall cable out through the adaptor and install the secure ring and adaptor to the bracket.
4. Connect the camera tail-cable to the wall cable. Insert the cable into the bracket.
5. Install the two screws, insert the camera body head into the adaptor and turn to hang the camera.
6. Lock up the chain-locker from camera body to the secure ring.
7. Screw in the adaptor to lock the camera tight.

This camera can provide SDI video output, IP video output separately and SDI + IP video outputs simultaneously.

The following sections are the instructions of how to use SDI video output and how to use IP video output.



Use SDI video output

Starting the Camera

After you have mounted the camera properly, connect the camera to power.

Each time the camera is powered on, it will perform a self-test to check the Pan/Tilt/Zoom (PTZ function). After self-test, you can operate the camera.

NOTE!

- The self-test process starts after the camera is powered up. Please wait patiently.
- When the operating temperature is lower than zero degrees Celsius, the camera will be automatically pre-heat (the pre-heat process takes 30 minutes at most). The self-test starts only after the temperature rises above zero degrees Celsius.

Connect Camera to Monitor/SDI Device

To view your camera, you need to use the coaxial cable to connect your camera to monitor or SDI device.

* The monitor/device must support the signal of HD-SDI or 3G-SDI.

Connect Camera with Controller

To control and configure your camera, you need to connect with control system (or control keyboard) for communication by RS-485/RS422. Set up the protocol of communication by control keyboard, the camera can auto detect VISCA and PELCO-D.

1. Connection

1.1 RS485 (PELCO D) control connection diagram

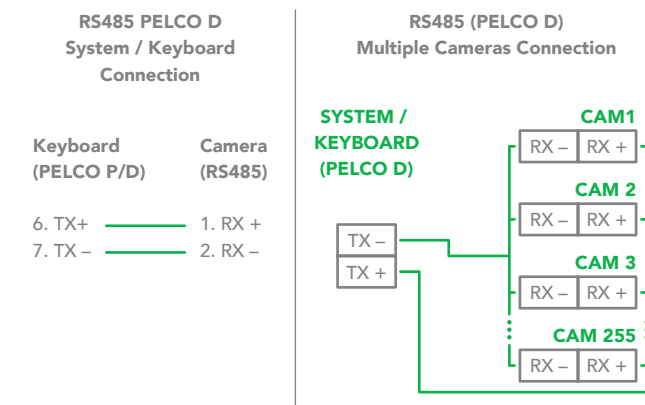

Connect the Camera's RS485+ and RS485- to RS485/TX+ and RS485/TX- on the control system/keyboard. The identity of the control system or equipment may be different; the corresponding relationship is as follows:

RS 485 A	RX +	RS 485 D+	RS 485 +
RS 485 B	RX -	RS 485 D-	RS 485 -

1.2 RS422 (VISCA) control connection diagram

- SONY Keyboard RS422 Connection

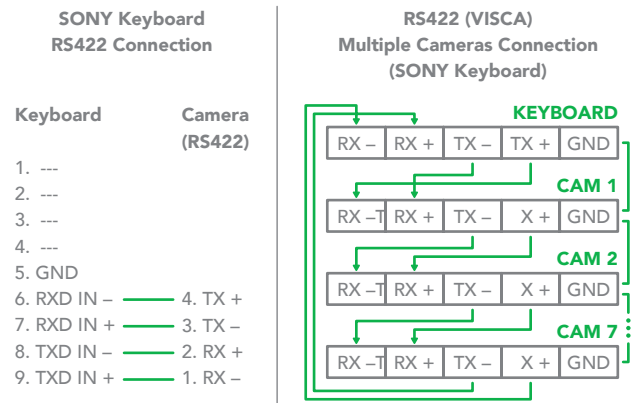

- VISCA (None-Sony) Keyboard RS422 Connection

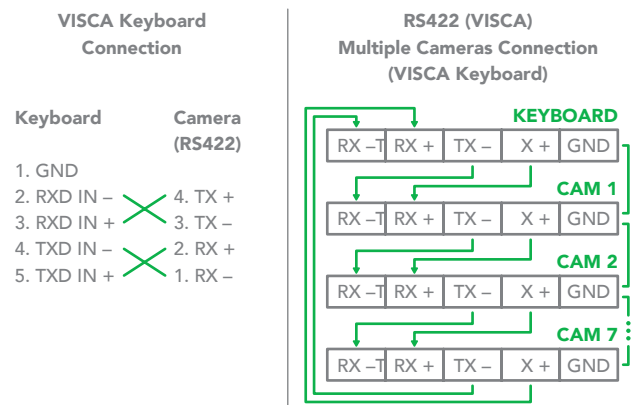

Setup Camera ID, Baud Rate and Control Protocol

In order for you to control a camera, the camera ID, baud rate and control protocol have to be set up in advance, Baud rate and the camera ID setting on the camera have to be the same as baud rate and camera ID setting on the system/control keyboard. The camera can auto detect the VISCA and PELCO-D, only need to set up the camera address and baud rate.

Connect the camera to a monitor. There is an initial setting page displaying on the screen for 5 seconds when the camera is powered on. On the page, it shows the factory default setting of the camera ID, baud rate and other information. Suggest taking a picture of this default setting information for setting keyboard use. Set the keyboard or control system to match the camera ID, baud rate setting with the camera.

1. Camera supports VISCA and PELCO-D protocols, protocol is detected automatically by the camera.
2. Factory Default Setting: For both SDI and IP video, Baud Rate: 9600, Camera ID: 001, Pelco Protocol.



3. Use RS485 Pelco-D can control up to 255 cameras, camera ID from 001 to 255 has to be set.
4. Use RS422 VISCA protocol can control up to 7 cameras, camera ID from 1 to 7 has to be set.
5. Supports baud rate of 2400bps, 4800bps, 9600bps and 38400bps.
6. How to set up the address and baud rate of the camera for SDI, please see the Page18.
7. On the keyboard side, for RS485 control, go into the camera setting menu, select the camera address/ID you want to set up for, set the baud rate to match the same as the one has been set on camera side, select protocol Pelco D for RS485 control. (How to set up the menu of the keyboard, please refer to the instruction of the keyboard you are using.)
8. On the keyboard side, for VISCA control, select RS232/RS422 control method, set the baud rate to match the same as the one has been set on camera side. (How to set up the VISCA keyboard, please refer to the instruction of the keyboard you are using.)
9. On IP control side, go into the camera IP web interface setting page by using browser to login camera IP address (Default set to 192.168.0.13), go to "Setup→System→Port&Devices" setting page, set the Baud Rate, camera ID, Protocol to the same as the ones that have been set on the camera side.
10. SDI and IP video setting have to be matching with each other, if you change any one of the settings on any sides of the SDI or IP.

RS485_1

Port Mode	PTZ Control ▼
Baud Rate	9600 ▼
Data Bits	8 ▼
Stop Bits	1 ▼
Parity	None ▼
Flow Control	None ▼
PTZ Protocol	PELCO-D ▼
Address Code	<input style="width: 50px;" type="text" value="1"/>
<input type="checkbox"/> Enable Trans-Channel	

NOTE!

- Regarding the camera ID and Baud Rate setting, for the first communication setting, you must match the control system (or keyboard) camera ID and Baud Rate setting to the cameras.

- After communicating successfully in between the camera and the control, you can modify the ID and baud rate of the camera using the keyboard.
- By default, the camera Baud Rate.

Controlling the Camera

The operation of the control systems or devices of different makers may be different. To operate the camera, please refer to the manual of the control system or the device.

Adjusting and Setting with Menus

About On-Screen Menus

You can change various settings, such as shooting conditions and system setup of the camera, while observing menus displayed on a connected computer screen. This section explains how to read the on-screen menus before starting menu operations.

The menu parameters may vary according to the different product model numbers. For a complete configurations menu, see "Menu Configuration" .

NOTE: You cannot perform pan/tilt operations while the menu is displayed.

Run preset 95th using keyboard to call/display the On-Screen Menu, the main menu will display on the screen.

How to run presets of cameras, please refer to the manual of the keyboard/control system that you are using.

How to adjusting and setting by joystick of keyboard

1. Push the joystick of the keyboard to the up or down: To select the menu that you want.
2. Push the joystick of the keyboard to the right: To enter the menu that you want.
3. Push the joystick of the keyboard to the right: To confirm the value that you want to set to.

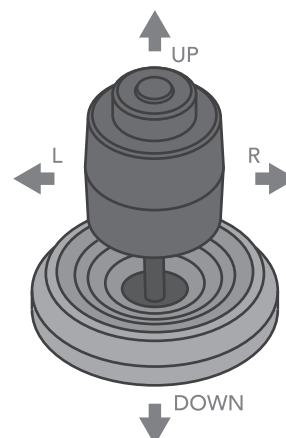

EXPOSURE Menu

The EXPOSURE menu is used to set the items related to exposure. **AE MODE** (Exposure Mode)

OSD	EXPOSURE MENU: FULL AUTO	
▶ EXPOSURE	AE MODE	FULL AUTO
WHITE BALANCE	IRIS	N/A
PICTURE	GAIN	N/A
LENS PARAMETERS	SHUTTER	N/A
SYSTEM SETUP	BRIGHT	N/A
FUNCTION SETTING	BACKLIGHT MODE	OFF
SAVE AND EXIT	WIDE-D	OFF
EXIT	DEFOG	OFF
	AUTO S. SHUTTER	OFF
	EX-COMP MODE	ON
	EX-COMP LEVEL	0 DB
	EXIT	

FULL AUTO: The exposure is adjusted automatically using the sensitivity, electronic shutter speed, and iris.

BRIGHT: Adjust the brightness level (LEVEL) manually.

SHUTTER: Shutter mode. The exposure is adjusted automatically using the sensitivity and iris. Adjust the electronic shutter speed (SPEED) manually.

IRIS PRI: Iris Priority mode. The exposure is adjusted automatically using the sensitivity and electronic shutter speed. Adjust the iris (IRIS) manually.

MANUAL: Adjust the sensitivity (GAIN), electronic shutter speed (SPEED) and iris (IRIS) manually.

When you select one from various exposure modes, some of the following setting items that are required for the selected mode appear.

GAIN: Select the gain from the following: -3, 0, 3, 9, 15, 18 dB

SPEED: Select the electronic shutter speed from the following: 1/1, 1/2, 1/3, 1/6, 1/12, 1/25, 1/50, 1/75, 1/100, 1/120, 1/150, 1/215, 1/300, 1/425, 1/600, 1/1000, 1/1250, 1/1750, 1/2500, 1/3500, 1/6000, 1/10000 sec.

IRIS: Select the iris the following: CLOSE, F14, F11, F9.6, F8.0, F6.8, F5.6, F4.8, F4.0, F3.4, F2.8, F2.4, F2.0, F1.6

LEVEL: Select the brightness level from 0 to 23.

BACKLIGHT MODE: When the background of the subject is too bright, or when the subject is too dark due to shooting in the AE mode, back light compensation will make the subject appear clearer. This is set to ON, OFF.

WIDE-D (Wide dynamic range mode): ON, OFF. The camera distinguishes light and dark areas within the same scene, adjusts the brightness for dark areas, and also controls the

blown out highlights.

DEFOG: ON, OFF. If the shooting scene has fog, you can open the defog function to improve the penetration of the image.

AUTO SLOW SHUTTER: ON, OFF. When AUTO SLOW SHUTTER is set to on, it can auto adjust the electronic shutter speed.

EX-COMP (Exposure Compensation): When MODE is set to one of FULL AUTO, SHUTTER PRI or IRIS PRI, set this item to ON to enable exposure compensation. When you set EX-COMP to ON, LEVEL appears and you can select the exposure compensation level from the following: -10.5, -9, -7.5, -6, -4.5, -3, -1.5, 0, +1.5, +3, +4.5, +6, +7.5, +9, +10.5

If you set the level to 0, exposure compensation will be disabled. Level +10.5 is the brightest and -10.5 is the darkest compensation value. When EX-COMP is set to OFF, exposure compensation does not function.

EXIT: Push the joystick to the right to exit this level menu.

WHITE BALANCE Menu

The WHITE BALANCE menu is used to select the white balance mode.

OSD	WITHE BALANCE: AUTO	
EXPOSURE	MODE	AUTO
▶ WHITE BALANCE	USER DEFINED R	203
PICTURE	USER DEFINED B	213
LENS PARAMETERS	EXIT	
SYSTEM SETUP		
FUNCTION SETTING		
SAVE AND EXIT		
EXIT		

MODE (white balance mode):

Select the white balance mode from the following:

AUTO, IN DOOR, OUT DOOR, ATW (Auto Tracing White Balance), OPW (One Push White Balance), USER, OUTDOOR AUTO, SLA (Sodium Lamp Auto), SL (Sodium Lamp), SLOA (Sodium Lamp Outdoor Auto).

When you select USER, R. GAIN (red gain) and B. GAIN (blue gain) appear. You can select each item in the range from 0 to 255.

EXIT: Push the joystick to the right to exit this level menu.

PICTURE Menu

The PICTURE menu is used to set the items related to the picture.

OSD	PICTURE MENU	
EXPOSURE	APERTURE	8
WHITE BALANCE	EFFECT	OFF
▶ PICTURE	COLOR GAIN	3
LENS PARAMETERS	COLOR HUE	7
SYSTEM SETUP	EXIT	
FUNCTION SETTING		
SAVE AND EXIT		
EXIT		

APERTURE: The aperture is used to adjust the picture edge sharpness. The value of the aperture is high, the edge of the picture more clearly, the value is low, more blurred. Select the aperture from the following: 0 - 15.

EFFECT: (Picture Effect)

It consists of the following functions:

Neg. Art: Negative/Positive Reversal

Black & White: Monochrome Image
Image effect from Off, B&W, NEG.ART

COLOR GAIN: 3 (Value :0~14)

COLOR HUE: 7 (Value: 0~14)

EXIT: Push the joystick to the right to exit this level menu.

LENS PARAMETERS Menu

The LENS PARAMETERS menu is used to set the items related to the lens.

OSD	LENS PARAMETERS MENU	
EXPOSURE	DIGITAL ZOOM	OFF
WHITE BALANCE	JOYSTICK RECOVER	NONE
PICTURE	A/F RECOVER TIME	000
▶ LENS PARAMETERS	A/I RECOVER TIME	000
SYSTEM SETUP	FOCUS NEAR LIMIT	30CM
FUNCTION SETTING	DAY/NITE MODE	NIGHT
SAVE AND EXIT	LASER	ON
EXIT	GAMMA	NORMAL
	ZOOMING SPEED	8
	PRESET SPEED	255
	EXIT	

DIGITAL ZOOM: ON, OFF. When DIGITAL ZOOM is set to on, it can use the digital zoom.

JOYSTICK RECOVER:

NONE: No effect.

A/F: After operate the camera, the mode of focus be changed to auto form manual.

A/I: After operate the camera, the mode of IRIS be changed to auto form manual.

AF-AI: After operate the camera, the mode of focus be changed to auto form manual, and, the mode of IRIS be changed to auto form manual.

A/F RECOVER TIME: When the camera is not in operation, if in the manual focus mode, after the A/F RECOVER TIME, it will automatically transfer to the automatic focus. If the time is 0, then the function is closed.

A/I RECOVER TIME: When the camera is not in operation, if in the manual Iris mode, after the A/I RECOVER TIME, it will automatically transfer to the automatic Iris. If the time is 0, then the function is closed.

FOCUS NEAR LIMIT: The near limit from the following: 1cm, 11cm, 30cm, 0.8m, 1.2m, 1.4m, 1.65m, 2.0m, 2.5m, 3.1m, 4.2m, 6.0m, 10m, 20m.

DAY/NITE MODE: You can select the mode from AUTO, DAY and NIGHT.

When the camera is set to **AUTO** mode, the camera will automatically turn from Day mode (Color) to Night mode (Black & White) when the lighting condition is low enough, the camera illuminator will be turned on automatically at Night mode.

When the camera is set to **Day mode**, the camera will stay in Day mode (Color) no matter how low the lighting condition is, the camera illuminator will not be turned on at Night. The image may be too dark to be seen in a low light condition.

When the camera is set to **Night mode**, the camera will stay in Night mode (Black & White) no matter how bright the lighting condition is, the camera illuminator will be turned on all the time. The image will be stay in Black & White.

LASER: ON/OFF. You can turn the Laser OFF when you don't need the illumination at all. When you turn the Laser ON, the illumination can be set to Day/Nite modes.

GAMMA: The gamma can be set to Auto, Manual, and value from 0 to 4.

ZOOMING SPEED: The speed of zooming can be set to value from 1 to 8.

PRESET SPEED: The speed of preset can be set to value from 1 to 255.

EXIT: Push the joystick to the right to exit this level menu.

SYSTEM SETUP Menu

The SYSTEM SETUP menu is used to set the items related to the camera system.

OSD	SYSTEM SETUP MENU	
EXPOSURE	FACTORY DEFAULT	
WHITE BALANCE	DISPLAY CONFIG.	
PICTURE	▶ INTERFACE SET	
LENS PARAMETERS	FLIP	OFF
▶ SYSTEM SETUP	SDI VIDEO	1080P30
FUNCTION SETTING	PAN DIRECTION	NORMAL
SAVE AND EXIT	TILT DIRECTION	NORMAL
EXIT	PROPORTIONAL PT	ON
	SET NORTH	
	SYSTEM INFO	
	SYSTEM RESET	

FACTORY DEFAULT: The menu is used to restore the factory settings.

DISPLAY CONFIGURATION: Entered the menu of DISPLAY CONFIGURATION, it will be shown the below items:

ZOOM LENS POSITION: Select ON to display the zoom lens position on the screen.

DIRECTION INDICATOR: Select ON to display the direction indicator on the screen.

INTERFACE SET: This menu is used to set the following:

CAMERA ID: Factory Default Setting: 001. Use RS485 Pelco-D can control up to 255 cameras, camera ID from 001 to 255 has to be set. Use RS422 VISCA protocol can control up to 7 cameras, camera ID from 1 to 7 has to be set.

BAUD RATE: Factory Default Setting: 9600. Select the baud rate from the following: 2400, 4800, 9600, 38400bps.

FACTORY FORMAT: Set factory default format.

NOTE!

- After the camera ID and Baud rate is set, to activate the new set camera ID and Baud rate, the camera has to be rebooted by powering the camera OFF and ON.
- For Dual-Output camera, the camera ID and Baud rate on IP web interface has to be set to the same ID as the camera's for IP control.
- You may need to reboot the keyboard after you change the camera ID and Baud rate.
- Once modified and saved the camera ID and baud rate, please modify the corresponding parameters on both the keyboard and IP web interface setting, otherwise

the camera and keyboard and IP control will be unable to communicate.

FLIP: Select ON to flip the image if you need to lift the camera.

VIDEO FORMAT: SDI + IP True Dual Output: You can have parallel SDI and IP video output. Either SDI or IP video format can be set up independently for having dual output simultaneously.

- SDI output: Select the SDI video output format from the following: 1080p 60, 59.94, 50, 29.97, 25; 1080i 60, 59.94, 50; 720p 60, 59.94, 50, 29.97, 25
- IP output: Select the IP video output format from the following: 1080P:30/25, 720P:30/25

Follow the steps to change the video format:

1. Set SDI video resolution in SYSTEM SETUP.
2. Select the SDI VIDEO format you want to have.
3. Waiting for a while for camera new set video format being taken. It is normal that you cannot take the control of the interface while the video format is being changed. You can reboot the camera by powering OFF and ON to active the new set video format if it takes too long to complete the format changing by itself.
4. Go to IP camera Web Interface), you can set IP video resolution.

PAN DIRECTION: NORMAL/INVERT. Supports normal and inverted directions on Pan movement.

TILT DIRECTION: NORMAL/INVERT. Supports normal and inverted directions on Tilt movement.

PROPORTIONAL PT: Turn ON to automatically adjust the Pan and Tilt speed with various zoom ratios. For example, the higher zoom ratio you use, the slower the speed of P/T. Turn OFF to inactivate the feature to set the flat speed of Pan and Tilt.

SET NORTH: Select ON to open this function. Turn the camera to the north, and then save it by call preset 1.

SYSTEM INFO: CAMERA ID, BAUD RATE, SDI VIDEO, IP VIDEO: Modify in the menu of "INTERFACE SET".

VERSION: The version of the software.

SYSTEM RESET: To save the changes have been made and make the changes activated.

EXIT: Push the joystick to the right to exit this level menu.

FUNCTION SETTING Menu

The FUNCTION SETTING menu is used to set the items related to the camera functionalities.

OSD	FUNCTION SETTING MENU
EXPOSURE	PRESET SETUP
WHITE BALANCE	TOUR SETUP
PICTURE	PATTERN SETUP
LENS PARAMETERS	SCAN SETUP
SYSTEM SETUP	IDLE TIMER 003
▶ FUNCTION SETTING	IDLE ACTION OFF
SAVE AND EXIT	EXIT
EXIT	

Note: The number of available presets may be limited by the head-ins, controllers, and DVRs that are connected to your dome system.

PRESETS SETUP: Preset is to store the PTZ information (such as: Pan and Tilt positions, focal length etc.) under the specific condition, and call the camera PTZ quickly to shoot to the specified location that you want the camera to move to.

Note: Presets not only save desired image positions, various picture settings such as brightness, exposure values, white balance and other variables are also saved and stored.

This function allows you to achieve the desired status instantly, even without adjusting the following items each time.

Pan/Tilt Position, Zoom Position, Digital Zoom On/Off, Focus Auto/Manual, Focus Position, AE Mode, Shutter control parameters, Bright Control, Iris control parameters, Gain control parameters, Exposure Compensation On/Off, Exposure Level, Backlight Compensation On/Off, White Balance Mode, R/B Gain, Aperture Control, WD Parameter.

The menu is used to manage the presets.

PRESETS NUMBER: The current preset number that you are managing.

PRESET MEMORY: ON/OFF When this feature is set to ON, All presets store camera positions and image parameters.

When this feature is set to OFF, 1-16 presets still store camera positions and image parameters, but 17-128 presets will only store camera positions. You can set the presets to number 17-128 if you don't want the preset to memorize the image parameter settings.

SET NEW PRESET: To set up the preset of the above preset number.

1. Push the joystick to the right to enter this setting menu, you will see "call preset 1 to end".

2. Adjust the camera to the position that you want the camera to be, and then call the preset 1 using the keyboard to save the position to be the current preset.

3. Finished.

DELETE PRESET: Delete the above preset.

1. Push the joystick to the right to delete this preset.

2. Finished.

EXIT: Push the joystick to the right to exit this level menu.

In order to use the special functions of the camera, the following presets are predefined for specific functions (You can find the default predefined preset at Web interface, Setup → PTZ → Advanced Settings):

OSD	OSD	SYSTEM SETUP MENU
54	SET	LENS RESET
55	CALL	OPEN BACKLIGHT
	SET	CLOSE BACKLIGHT
56	CALL	OPEN AUTO SHUTTER
	SET	CLOSE AUTO SHUTTER
57	CALL	OPEN SCREEN DISPLAY
	SET	CLOSE SCREEN DISPLAY
58	CALL	OPEN DIGITAL ZOOM
	SET	CLOSE DIGITAL ZOOM
59	CALL	DISABLE WDR
	SET	ENABLE WDR
60	CALL	AUTO IRIS
	SET	MANUAL IRIS
61	CALL	AUTO WHITE BALANCE
	SET	MANUAL WHITE BALANCE
63	CALL	IMAGE NORMAL
	SET	IMAGE FLIP
64	CALL	COLOR MODE
	SET	BLACK AND WHITE MODE
65	CALL	AUTO DAY/NIGHT MODE
95	SET	OPEN MENU
97	CALL	START PATROL
	SET	SET PATROL ROUTE
99	CALL	AUTO FOCUS
	SET	MANUAL FOCUS

TOUR SETUP: The menu is used to manage the tours. Total of 4 tours can be managed.

SEQUENCE NUMBER: The current tour number that you are managing.

DEFAULT DWELL: Set the interval time between each of presets in the above tour, the value can be selected from 3 to 255 sec.

EDIT SEQUENCE: Set up the above tour.

1. In the order of 1, 2, 3, ... , 6, add each of preset and default dwell time to the tour.
2. The tour path will be set based on the presets and default dwell have been set in step one.

PRESET NUMBER	DEFAULT DWELL	PRESET NUMBER	DEFAULT DWELL	PRESET NUMBER	DEFAULT DWELL
1	000	2	000	3	000
4	000	5	000	6	000
000	000	000	000	000	000
000	000	000	000	000	000
...

RUN CONTINUOUSLY: start the tour has been set.

EXIT: Push the joystick to the right to exit this level menu.

PATTERN SETUP: A pattern is a memorized, repeating series of pan, tilt, zoom, and preset functions that can be recalled with a command from a controller or automatically by a programmed function (alarm, park, event, or power-up).

The menu is used to manage the patterns. Total of 4 patterns can be managed.

PATTERN NUMBER: The current pattern number that you are managing.

RECORD NEW PATTERN: Set up the above pattern.

1. Push the joystick to the right to enter this setting menu.
2. Move the camera to the start position you want, and then call the preset 1 to save.
3. Move the camera to each position you want to record the pattern, and then call the preset1 to end.
4. Finished.

RUN CONTINUOUSLY: start the above pattern.

EXIT: Push the joystick to the right to exit this level menu.

SCAN SETUP: The menu is used to manage the scans. Total of 4 scans can be manage.

PANNING NUMBER: The current scan number that you are managing.

SET LEFT LIMET: Set the left limit of the camera scan.

1. Push the joystick to the right to enter this setting menu.

2. Move the camera to the left limit position that you want, and then call the preset 1 to save.

SET RIGHT LIMET: Set the right limit of the camera scan.

1. Push the joystick to the right to enter this setting menu.
2. Move the camera to the right limit position that you want, and then call the preset 1 to save.

DEFAULT SPEED: Set the interval time from left to right during Scanning, and select value from 3 to 255 sec.

RUN CONTINUOUSLY: start the above scan.

EXIT: Push the joystick to the right to exit this level menu.

IDLE TIMER: If the camera stays in No-operation for certain amount of IDLE Time, the camera would take action automatically.

The menu is used to set the IDLE time, and value can be selected from 0 to 255 sec.

IDLE ACTION: After the IDLE time, the camera starts the IDLE action automatically.

Even if the idle time's value is set to 0, or during the IDLE time, manual operation will always have the priority to the response.

The menu is used to select the IDLE action.

The IDLE action can be selected from: OFF, PRESET1-220, SCAN1-4, TOUR1-4, PATT1-4.

EXIT: Push the joystick to the right to exit this level menu.

EXIT

Push the joystick to the right to exit the menu. All the setting modifications will be saved.

Dimensions

Unit: mm

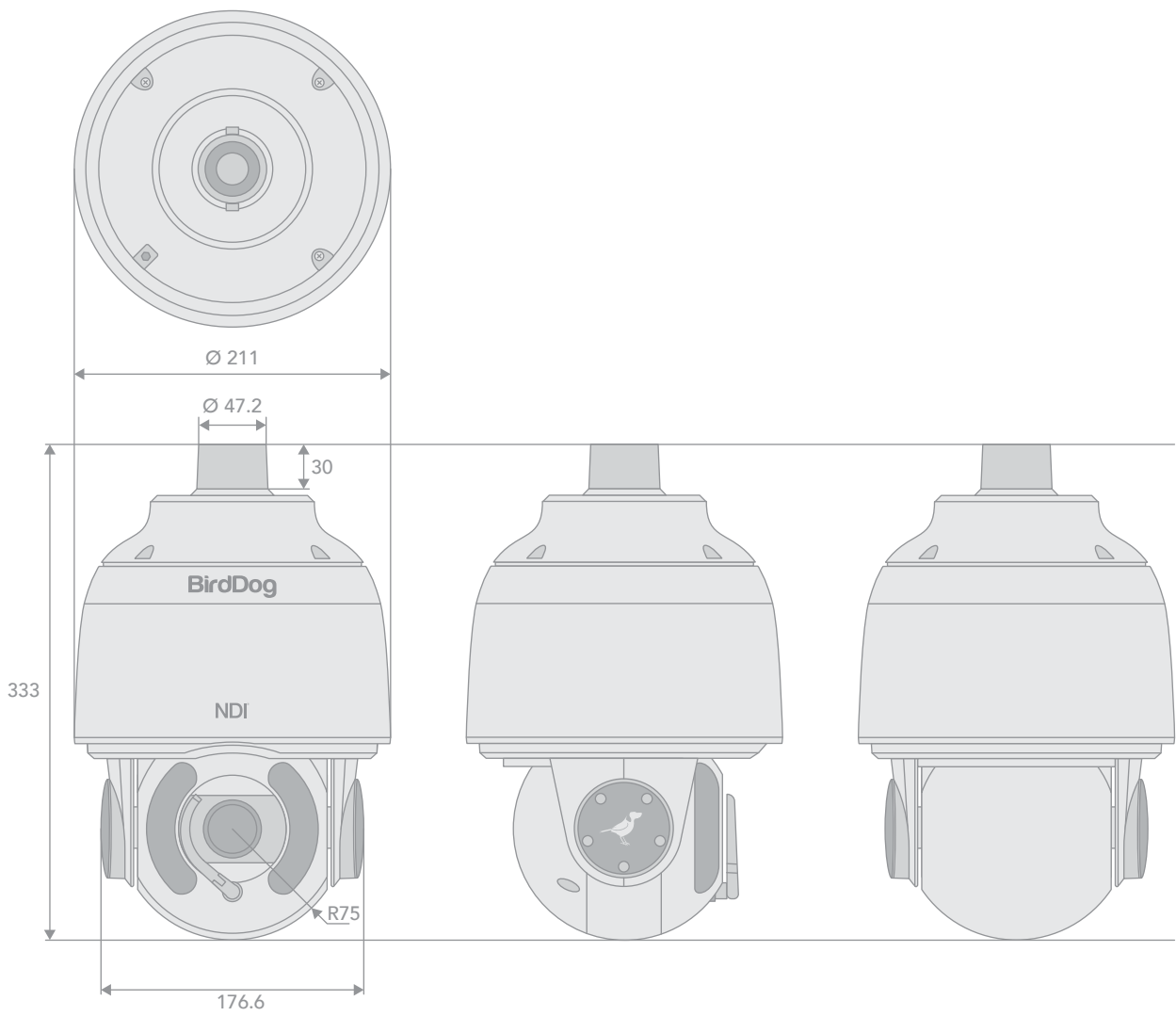





WELCOME TO THE FUTURE.

bird-dog.tv

hello@bird-dog.tv